

NetGain Motors, Inc.

800 South State Street / Suite 4 / Lockport, IL 60441 / 630-243-9100 / 630-685-4054 (FAX)

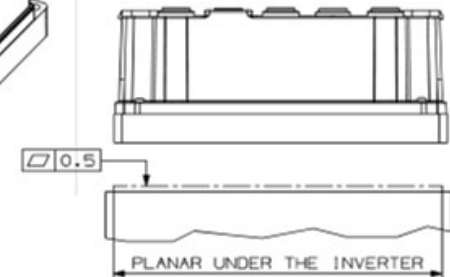
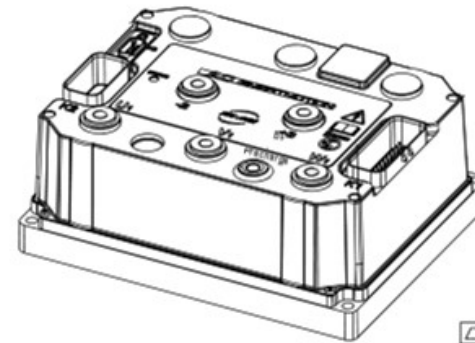
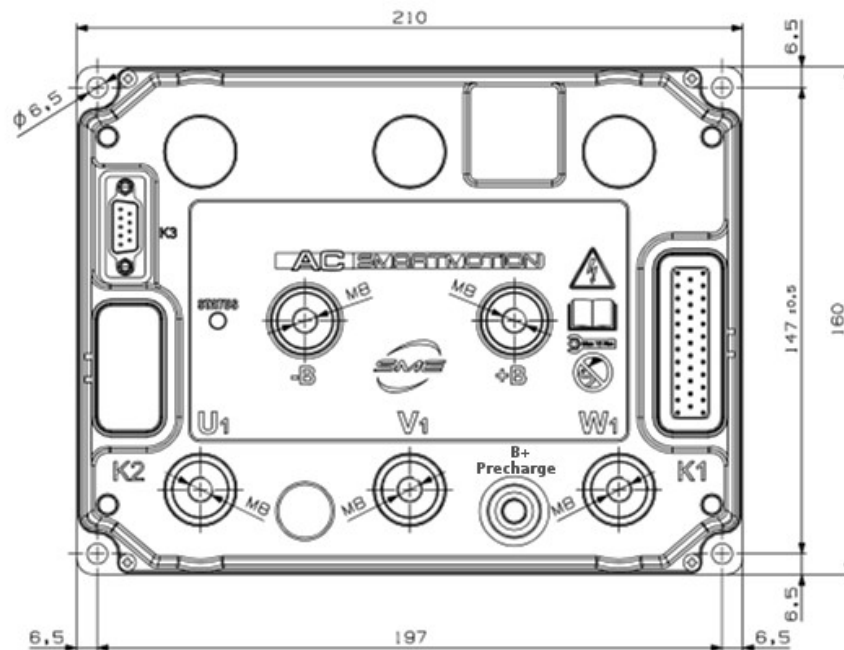
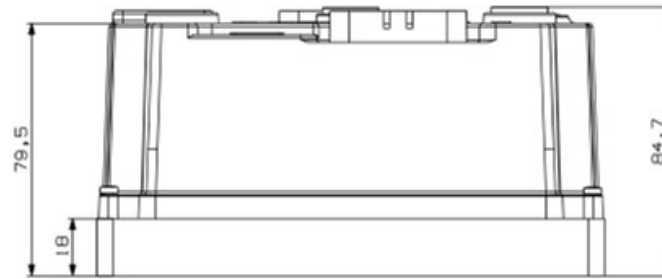
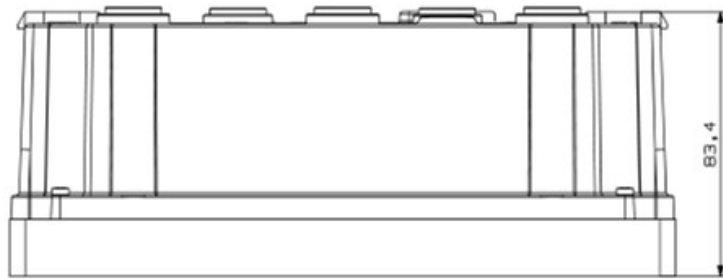

MOUNTING RULES	
SUGGESTED THERMAL GREASE TYPE : HTS ELECTROLUBE	
PAINT OF PLANE UNDER AC PANEL MUST TO BE THERMIC CONDUCTIVE	
FIXING MAX TORQUE FOR THE AC PANEL M6 SCREWS IS 6,5Nm	

K1 CONNECTOR AMPSEAL 35 POSITIONS	
PLUG ASSEMBLY	cod.776164-1
CONTACT 0,5-1,4mm ²	cod.770854-1

UNIT OF MEASUREMENT: mm	
K3 CONNECTOR 9 POSITIONS	
SUB-D FEMALE STANDARD DENSITY	

Hyper-Drive X144™

